

# Multi-Channel PD Measurements on Transformers – A New Approach for Real-Time Data Evaluation

Kay Rethmeier, Wolfgang Pichler, Michael Krüger  
OMICRON electronics GmbH  
Oberes Ried 1  
A-6833 Klaus  
AUSTRIA

Ronald Plath, Caspar Steineke  
OMICRON electronics GmbH Berlin  
Lehrter Straße 16-17  
D-10557 Berlin  
GERMANY

## Abstract

Partial discharge measurements on transformers and rotating machines are an accepted tool of quality control, in factory and on site. Common methods to improve the quality of noisy PD data are filtering and gating. Recently a new method was introduced, which is able to clearly separate different PD sources within the DUT as well as separate PD from noise. This multi-channel synchronous measuring method compares amplitude relations of simultaneous PD sources of three phases (3PARD).

PD pulses propagate from its origin to the decoupling site, even cross-coupling to the other phases. PD from different locations inside the insulation will lead to unique pulse triples at the 3 decoupling positions. The amplitude relations of the 3 synchronous decoupled pulses of one pulse source will be nearly constant. That allows a classification of different noise sources and single PD failures within the DUT by comparison of these amplitude relations.

As a new approach of PD source separation the 3PARD method was adapted to the 3-Center-Frequency-Relation-Diagram 3CFRD. This technique allows PD and noise separation by the comparison of the frequency spectrum of different PD mechanisms and noise pulses. In real-time a diagram can be constructed with similar clusters as the familiar 3PARD. As 3CFRD is not inevitably linked to 3-phase systems like power transformers it can also be applied on single phase transformers, VTs and CTs. This paper will present promising results from the latest multi-channel PD measurements.

## Introduction

Partial Discharge (PD) measurement is a worldwide accepted tool for quality control of high voltage (HV) apparatus [1]. Outside screened laboratories, PD signals are very often superposed by noise pulses, a fact that makes a PD data analysis more difficult for both human experts and for software expert systems. Therefore the handling of disturbances is one of the main tasks when measuring PD. Additionally, with the ongoing development of permanently installed PD monitoring systems the PD data analysis needs to become more effective to be done automatically. By using synchronous multi-channel PD acquisition it is possible to gain de-noised PD data from separated PD sources in order to make PD measurements more reliable.

PD measurements are often performed under noisy conditions. The PD signal is superposed by stochastic noise pulses or even multiple PD sources, which will lead to a complex phase resolved PD pattern that is not easy to analyze. Conventional frequency filters are not able to eliminate these pulse-shaped disturbances. PD experts and automatized computer expert systems will have difficulties with the superposition of multiple PD faults and noise. Some well-known evaluation techniques as pulse-sequence-analyses will even fail with non-correlated PD pulses to be compared. Separating PD from noise and separating multiple PD sources must be the first step to de-noise PD data. In the future this will become even more important with the rising numbers of automated PD monitoring systems installed at critical network points.

## Multi-Channel PD Data Acquisition

Beside advanced mathematical PD analyzing algorithms concentrating on single-channel PD measuring results a huge advantage can be taken by collecting synchronous PD data from multiple decoupling positions. This may be a widespread HV cable system of some kilometers length with PD decoupling at

all joints [2] or a 3-phase power transformer with synchronous PD decoupling at the 3 (or even more) high voltage windings.

### PD Analyzing System

The MPD 600 as a modern type of a fully digital PD measuring system is capable of performing synchronous multi-channel PD measurements. A brief overview of this system will be given here (more detailed information in the product specification [3] and type test description [4]). This measurement system consists of one or more acquisition units (fig. 1), an optical interface (FO bus-controller) and a PC including the measuring software.

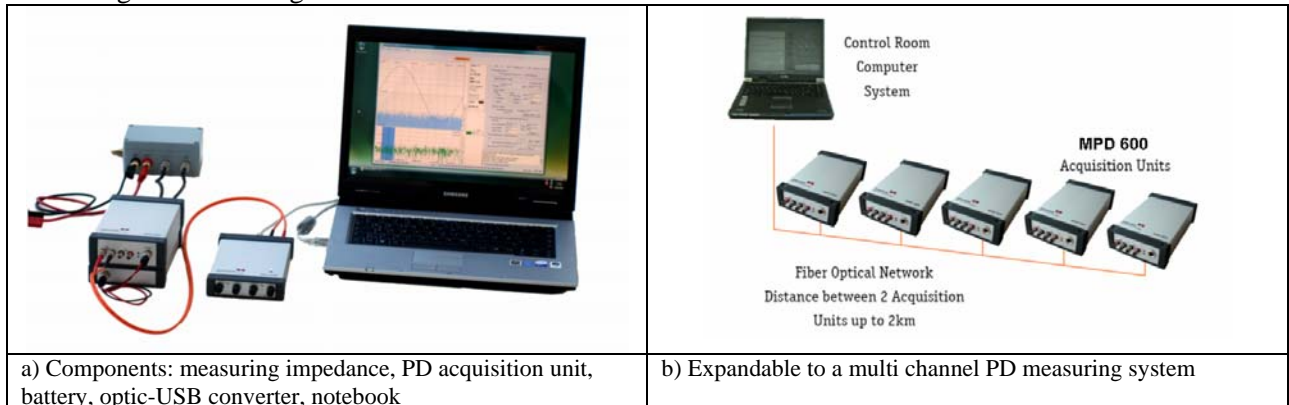

Fig. 1: MPD 600 PD measuring system

The PD signals are filtered, amplified and digitized. An optimum frequency band can be chosen to avoid continuous-wave disturbances and to reach a high SNR (signal-to-noise-ratio) even under noisy conditions on site. For multi-channel PD measurements up to 960 acquisition units can be connected to one PD system (see also fig. 1b) while a maximum number of 64 units can be operated in a fully synchronized mode.

### Evaluation Methods

A new field of evaluation methods is opened by fully synchronous multi-channel PD acquisition in order to gain more reliable measuring results combined with effective noise suppression. Therefore the 3-Phase-Amplitude-Relation-Diagram (3PARD) was presented [5] as a new powerful analyzing tool to distinguish between different PD faults and noise pulses when measuring 3-phase high voltage equipment like power transformers [6], rotating machines [7] and cross-bonded cable systems [8]. As an enhancement of 3PARD the 3-Center-Frequency-Relation-Diagram (3CFRD) is introduced as an additional tool for PD data analysis and PD fault separation in real-time. The synchronous consideration of three different frequency parts of the PD spectrum of a single PD pulse gives a conclusion of its discharge nature and indicates its possible PD fault location due to PD signal propagation and attenuation.

#### 3-Phase-Amplitude-Relation-Diagram (3PARD)

Due to the coupling of the 3 phases within a transformer (galvanic, capacitive and electro-magnetic) a single PD pulse of a certain phase can be measured as voltage signal in all phases and acquisition units, respectively. Figure 2a shows a schematic view of three acquired PD voltage signals in the time-domain related to the same PD fault in phase L1. As L1 is the source of the PD fault the amplitude is highest there. Due to the galvanic coupling of the three phases (common neutral point of the transformer, for instance) the voltage signal can also be measured in phases L2 and L3, with reduced amplitudes due to the attenuation of the additional windings. In order to create a two dimensional color coded 3PARD the amplitude vectors of the 3 phases are added with 120 degree phase shifting (in accordance to the phase shift of the test voltage). PD pulses are mainly located within clusters next to the axes of the diagram. Pulses due to noise (nearly same amplitudes) are placed next to the origin. Therefore a clear separation of PD and noise is possible by selecting specific 3PARD clusters for real-time re-transformation to classical PRPD patterns.

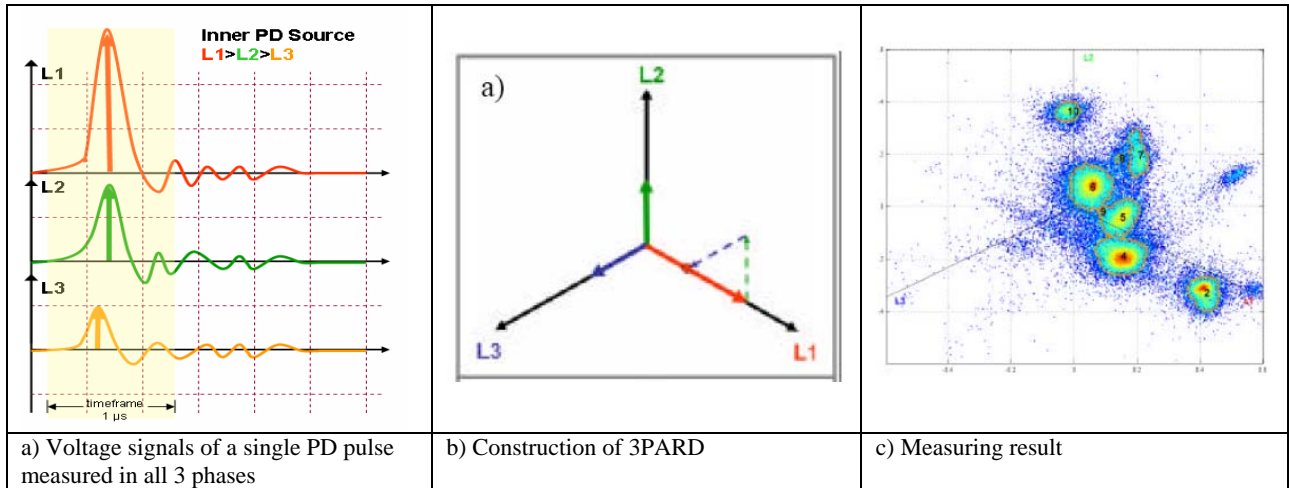

Fig. 2: Creating 3PARD from PD voltage signals

Figure 2c shows a 3PARD created from real PD data acquired at a PD measurement on a 10 kV high voltage motor with major PD activity on phases L1 and L2. As the position of the clusters indicate a certain relation to the phase the color represents the number of PD pulses acquired at the same position in the 3PARD (red = high pulse activity).

As every cluster in figure 2c represents a different PD source within the machine, (except cluster 6 and cluster 9 representing noise pulses) the on-line and real-time back transformation of a single cluster will lead to a PRPD pattern of only a single PD fault (in case of only one PRPD pattern with the confusing superposition of all PD faults and noise). The interpretation of this cleaned-up PRPD pattern is considerably easier for the PD expert performing the measurement.

### 3-Center-Frequency-Relation-Diagram

3PARD can be created by any synchronously gained pulse triples. Even for a single-phase or a single PD decoupling position pulse triples can be acquired by using three different PD filter settings, for instance. So the signal output of three filters with different center frequencies or bandwidths allows a pulse-waveform-analysis. The correlation of PD filter settings and diagram axis is shown in figure 3a.

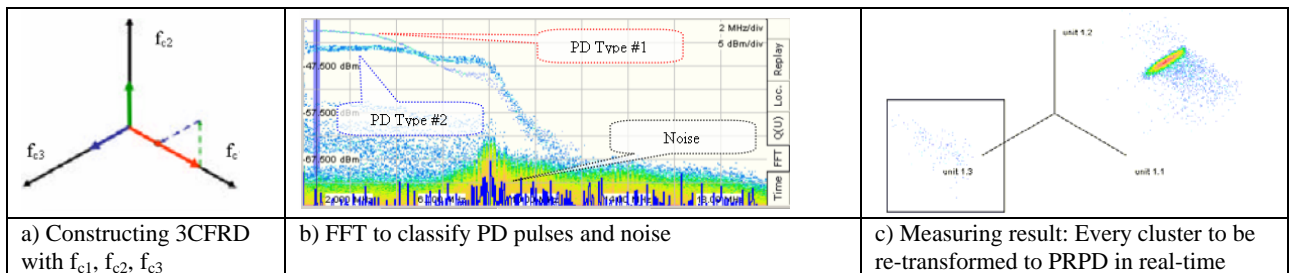

Fig. 3: 3CFRD method

This refers to the fact that, due to the discharge physics, different PD types or noise pulses relate to different but characteristic energy-frequency spectrums, as can be seen in figure 3b. By comparing the filter output of different PD-types these types can be distinguished, when proper frequency settings are selected. A separation of different PD sources and different noise sources is possible by focusing on single 3CFRD clusters (see fig. 3c). A real-time back-transformation will result in clear and de-noised phase resolved patterns of single PD sources.

### Dealing with Interferences

The main problem during PD measurements is the handling of interferences. PD measurements outside a screened laboratory will always be interfered by external disturbances, as radio transmitter stations, corona from nearby systems or stochastic pulses caused by switching activity in the grid or from power electronics components.

Due to the different nature of these disturbance pulses they have to be dealt with in specific ways.

## Continuous Wave Interference

As PD detectors normally are designed as a filtering system (a band pass filter, for instance), the PD measurement can be performed in a spectral area with no or low interference level. Therefore it is very helpful if the PD measuring instrument allows flexible filter settings, as a free choice of filter bandwidth  $\Delta f$  and center frequency  $f_c$ .

It has to be pointed out that filtering in frequency domain will not affect pulse disturbances, as these noise pulses have a similar frequency characteristic compared to real PD pulses.

## Gating of Phase-Fixed Disturbances

With the widespread use of power electronics components a new class of disturbances becomes increasingly frequent during PD measurements. It can be observed that phase-fixed disturbances superpose the measuring result with a certain number of pulses of similar amplitude. Figure 4 shows a phase-resolved PD pattern (PRPD) with disturbance pulses caused by a mobile AC resonance test system and its influence on the measured charge level  $Q_{IEC}$ .

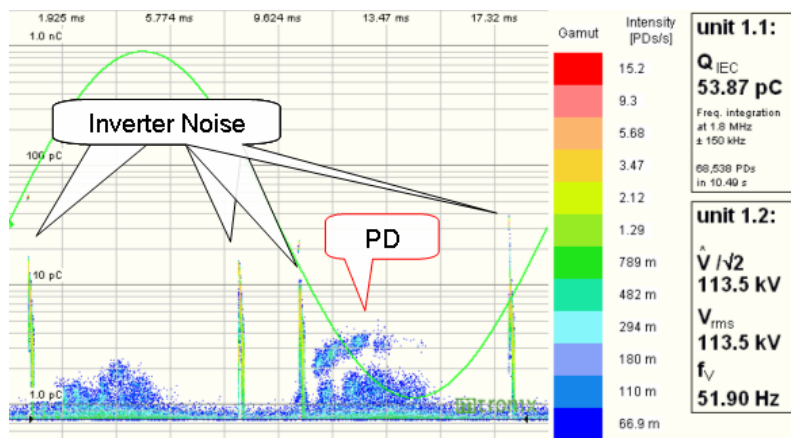

The PRPD pattern shows PD activity with a magnitude below 5 pC from the DUT. The displayed charge value  $Q_{IEC}$  indicates a significantly higher charge value of more than 50 pC. This reading is in fully accordance to IEC 60270, but it was caused by the switching pulses of the inverter. Therefore these phase-fixed disturbance pulses have to be gated to avoid an influence on the numeric value and to avoid wrong interpretations of the measured result.

Fig. 4: PRPD pattern of PD and inverter pulses from AC resonance test system

Figure 5a shows a PRPD pattern of PD activity superposed by phase-fixed noise of a 6-pulse bridge. As the phase positions of the disturbance pulses are known they can easily be gated by applying gating windows via software. Figure 5b shows the PRPD pattern and the numeric  $Q_{IEC}$  value of the revised PD data.

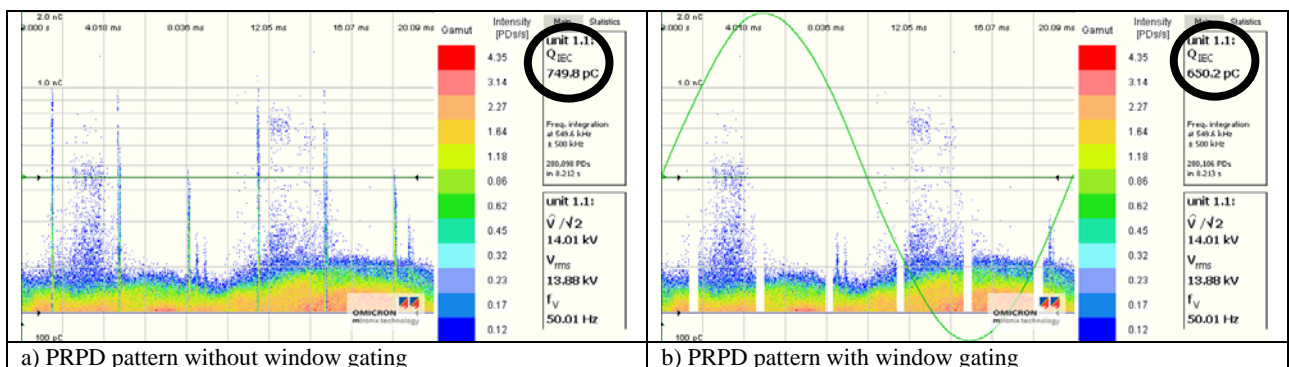

Fig. 5: PRPD pattern of PD and phase-fixed noise pulses

## Gating of Disturbances with Stochastic Phase Position

As some pulse disturbances are not fixed in their phase positions it becomes more difficult to handle them. With their stochastic character they are very similar to PD pulses. With all effort to gate disturbance pulses it must be prevented at all time that real PD pulses are gated, too.



Fig 6: PD test setup according to IEC 60270 with test voltage source, coupling capacitor and test object (VT)

In order to be able to differentiate between PD and random noise pulses a Dynamic Noise Gate can be applied to the PD data. This algorithm analyzes the phase position of pulses (PD or noise pulses) and its repetition rate at this specific phase position. For consecutive test voltage periods a single PD pulse is more or less constant in its phase position (in accordance to its physical discharge mechanism it will jitter some degrees in phase position). It occurs approximately once per period or once per half-cycle. By contrast a stochastic noise pulse will not occur in the same phase area for consecutive test voltage periods. The mathematical differentiation can easily be realized by a pulse counter for a certain number of phase sections (phase classes). The gating mechanism is shown for a PD measurement on a 145 kV voltage transformer performed in a non-screened HV-laboratory of a manufacturer (see figure 6).

Figure 7 shows the result of Dynamic Noise Gating for the same set of PD data recorded during a PD measurement at approx. 87 kV test voltage level at 120 Hz test voltage frequency.

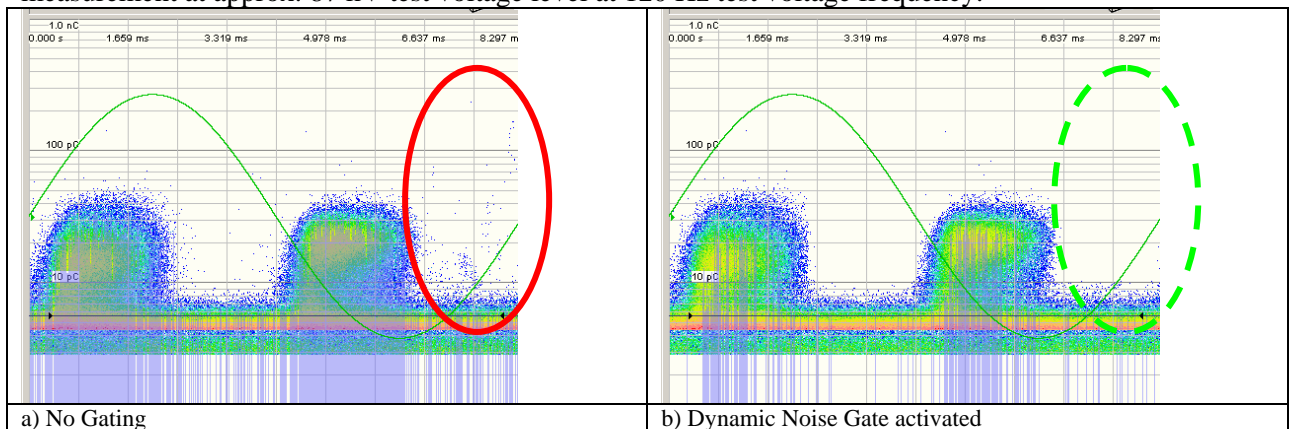

Fig. 7: PRPD patterns of PD measurement on a 145 kV VT

During the PD measurement the numeric  $Q_{IEC}$  value shows significantly high readings for a short time, obviously caused by disturbance pulses. Figure 7a shows some of these disturbance pulses in the PRPD pattern within the red ellipsis. With the Dynamic Noise Gate activated these pulses are effectively eliminated, as to be seen in the PRPD pattern of figure 7b (dashed, green ellipsis).

For this example the total number of removed disturbance pulse was 584, which means only 0.1% of the whole recorded PD data. No high readings of the numeric  $Q_{IEC}$  value caused by disturbance pulses could be seen during the PD test with activated gating functionality.

### Noise Suppression by External Unit Gating

With the possibilities of fully synchronous PD data acquisition a second PD measuring unit can be used for detecting external disturbance pulses not correlated to the DUT. Therefore the second acquisition unit must not be directly connected to the PD measuring circuit directly, but decoupled from the test object.

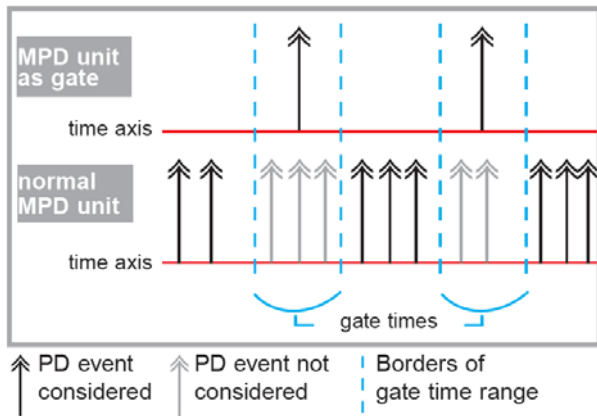

Fig. 8: Principle of unit gating

It has to be ensured, that this gating unit cannot acquire PD pulses but only interference pulses. Typical ways to connect a gating unit are inductive decoupling from a ground connection or an antenna. Figure 8 describes the principle of unit gating.

The PD acquisition unit detects both, PD pulses and disturbance pulses. If the gating unit detects a pulse, this will influence the PD data processing of the PD acquisition unit. For a certain gating time no pulse events will be considered. These gated pulses will not influence the  $Q_{IEC}$  reading and they will not be plotted in the phase-resolved PD histogram.

### 3PARD Gating

The synchronous acquisition of PD data for all three phases of an HV apparatus allows a pulse-per-pulse amplitude comparison. As a result a 3PARD clustering can be performed. Figure 9 shows the result of a 3-phase PD measurement on a 30 MVA / 115 kV power transformer.

Figure 9a shows the complete PRPD data recorded at phase L1. It can be seen that the pattern consists of background-noise (horizontal area, distributed all over the test voltage phase), PD activity and phase-fixed disturbances (located approx. at  $60^\circ$  and  $240^\circ$  phase position). These three different components of the PRPD pattern can be real-time separated in the 3PARD visualization, as to be seen in figure 9b. Every single 3PARD cluster can be re-transformed in order to analyze it in the PRPD view. As the final result figure 9c shows only the relevant PD data of the red-marked 3PARD cluster with background noise and pulse-noise suppressed effectively.

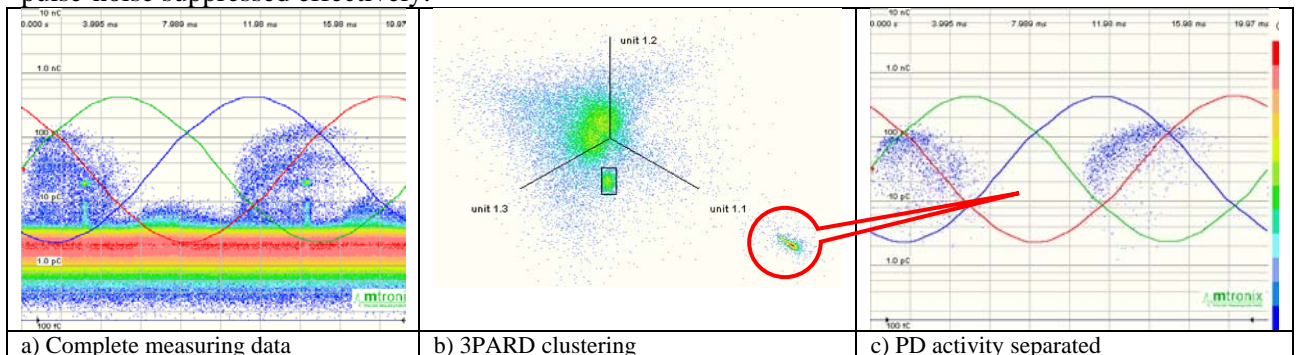

Fig. 9: Gating noise by 3PARD

### 3CFRD Gating

The 3PARD method requires PD pulse triples. Three PD amplitudes are compared and plotted into a single diagram to form separable clusters. However, this type of diagram can generally be created by any synchronously gained pulse triples.

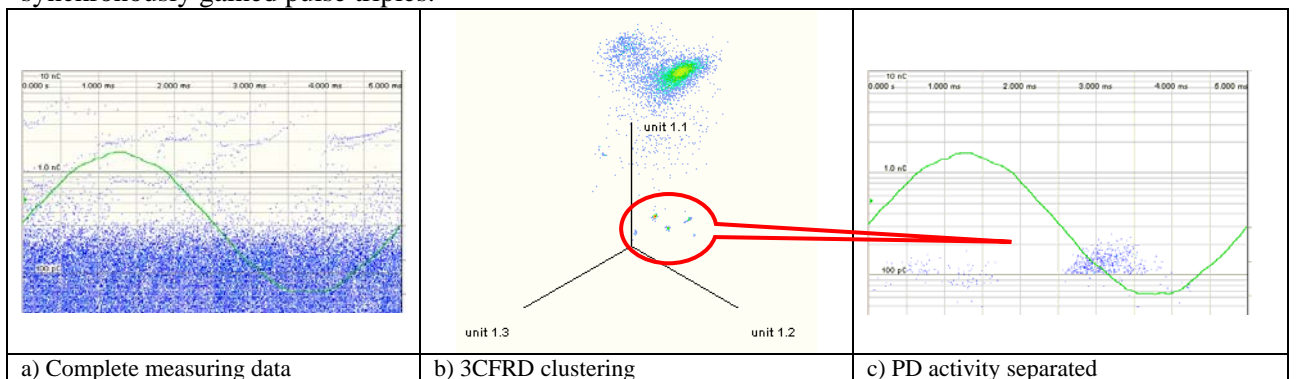

Fig. 10: Gating noise by 3CFRD

Even for a single phase or a single PD decoupling position pulse triples can be gained by using three different PD filter settings, for instance. So the signal output of three filters with different center frequencies or bandwidths allows a pulse-waveform-analysis. This refers to the fact that, due to the discharge physics, different PD types or noise pulses have different but characteristic energy spectrums. A separation of different PD sources and different noise sources is possible by focusing on single 3CFRD clusters. A real-time back-transformation will result in clear and de-noised phase resolved patterns. Figure 10 shows the results of a PD measurement on a 500 kVA 240 V/10.5 kV dry-type transformer. It can be seen that the present PD activity cannot be seen without the 3CFRD gating technique due to heavy disturbances during the measurement.

### **PD Location on Power Transformers**

Instead of only providing a numeric value the result of a PD measurement should allow to estimate the condition of the test object. It has to be investigated whether the PD fault will cause ongoing degradation or damage to the dielectric insulation. This assessment depends very much on the position of the PD fault within the test object. With the knowledge of the dielectric material and the prospective maximum electrical field strength at this certain position a risk assessment becomes possible.

For locating PD faults inside a transformer acoustical methods are very common. Due to the noise emission of the internal discharge a sound wave propagates through the tank. By comparing the time differences for different acoustic sensors a triangulation can be done to locate the source. The reliability of this method strongly depends on the inner structure of the transformer, as different materials have different propagation speeds. Also the sensitivity is not very good due to high sound attenuation during wave propagation. For more sensitive measurements electromagnetic methods (or a combination of electrical triggering and acoustic location) are required. To minimize the constructive effort for a PD measurement the discharges should be decoupled via the measuring tabs of the transformer's bushing or by connecting coupling capacitors to the conductors of the bushings. The injection of special UHF probes inside the transformer's tank, however, could be seen as a dangerous intrusion to the insulation system.

### **PD Location on Power Transformers by Multi-Channel Data Acquisition**

Synchronous multi-channel PD acquisition can be used to locate PD sources within a transformer. Therefore the measuring results of two or more PD acquisition units have to be compared for single PD pulses as a single PD pulse may be detected via more than one acquisition unit. This is possible, for example, when measuring three phases of a transformer at the same time and comparing the pulse cross-talk to the neighbor phases. This will result in a 3PARD analysis (comparing pulse amplitudes) or in a time-of-flight analysis (dual end measurement) when comparing the time-of-arrival of pulses at different locations.

#### **3PARD**

The 3PARD method allows a clear allocation of PD sources to a certain phase by considering the PD cluster position in the 3PARD diagram. PD clusters close to the axis of phase 1 (for instance) are caused by a PD fault located in the winding of this axis. With multiple PD faults within the transformer additional clusters will appear in 3PARD, allocated to the referring phases.

If the PD fault is once allocated to a certain phase its position within the winding can be estimated by analyzing the exact PD cluster position in 3PARD. For a transformer with star windings a 3PARD cluster close to the origin of the diagram refers to a PD fault close to the neutral. With greater distance from the diagram's origin the PD fault will be located at a greater distance to the neutral. The maximum distance of a 3PARD cluster to the origin indicates PD activity coming from the transformer's bushing. This cluster position with the maximum distance to the 3PARD origin can be defined during calibration process. With a charge calibrator connected to the terminals of a bushing a PD discharge is simulated at this position.

As a matter of fact, an exact geometrical PD fault location can not be done with 3PARD analysis. In many cases a rough geometrical estimation of the PD source (PD close to the bushing, PD coming from the middle of the winding, PD close to the neutral) will be sufficient and a great help for the test engineer.

## Dual End Measurement (Time-of-Flight Analysis)

A PD pulse within a transformer can propagate from its origin to the place of PD decoupling. This propagation process can be electromagnetic, capacitive or galvanic along the dielectric of the windings (or a combination of these mechanisms).

For the galvanic pulse propagation the transformer's winding can be seen as a propagation line, similar to a HV cable. Therefore the PD location techniques known from cable systems or cable drums can be transferred to the transformer in principle. Figure 11 shows a dual-end-measurement result (time differences between phase L1 and phase L3) of a PD fault location at a power transformer.

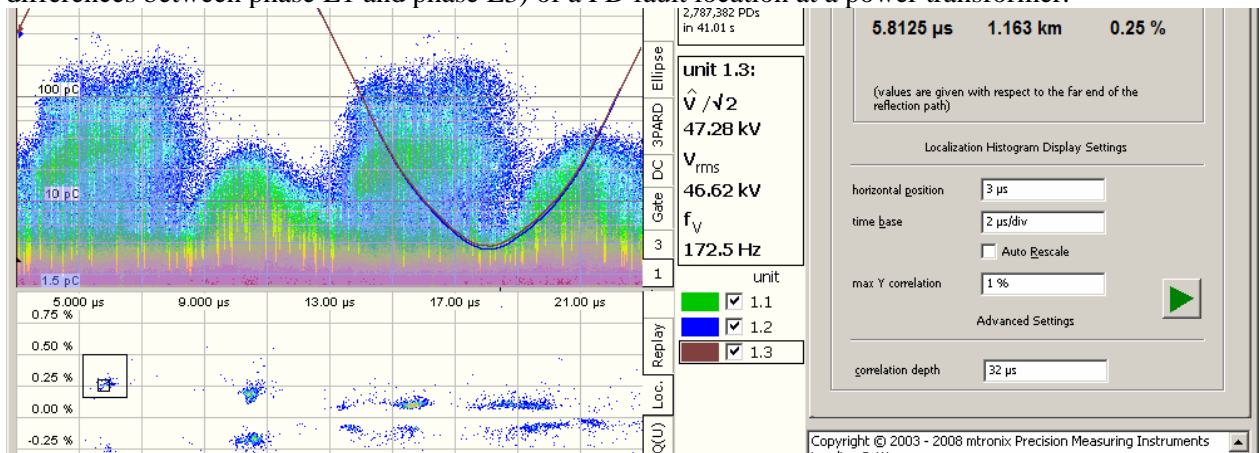

Fig. 11: PD fault location by synchronous dual-end-measurement method

The lower diagram shows the occurring time differences of consecutive PD pulses (horizontal axis) and its amplitude ratio (vertical axis). The marked clusters stand for multiple PD pulses with a time difference of approx.  $5.8\mu\text{s}$ . With the 1<sup>st</sup> PD pulse detected with 100% amplitude, the 2<sup>nd</sup> one only shows 0.25% of the original amplitude due to strong signal attenuation. With an estimated pulse propagation speed the geometrical fault location on the HV winding can be calculated.

## Summary

The separation of multiple PD sources and noise is absolutely mandatory for a clear PD data analysis. By handling single PD faults, PRPD patterns and pulse-sequence analysis will work best in order to deliver reliable results. Synchronous multi-channel PD measurements provide new and advanced options of PD evaluation such as 3PARD, 3CFRD and dual-end-measurements. Therefore a powerful hardware is needed to allow synchronous PD acquisition in a time frame of a few nanoseconds and real-time data-handling. The presented digital PD measuring system is capable of performing this kind of measurements, as proven in many PD tests in the laboratory and especially under noisy on-site conditions.

## Literature

- [1] Smit: "Trends in PD-diagnostics for Asset Management of Aging HV Infrastructures" -14th International Symposium on High Voltage Engineering, Beijing/P.R.China, 25-29th August 2005
- [2] Sutton, Plath and Schroeder: "The St. Johns Wood – Elstree Experience – Testing a 20km long 400kV XLPE-insulated Cable System after installation", 7<sup>th</sup> International Conference on Insulated Power Cable Jicable07, France, Versailles, 2007
- [3] Omicron electronics: "MPD600 - Product brief and specification", Austria, 2007
- [4] Holle, Plath, Schon and Lucas: "Type testing a digital PD measuring system according to IEC 60270", ETG conference on Diagnostic, Kassel, Germany, 2006
- [5] K.-D.Plath, R.Plath, Emanuel and Kalkner: "Synchrone dreiphasige Teilentladungsmessung an Leistungstransformatoren vor Ort und im Labor", ETG conference on Diagnostic, Berlin, Germany, 2002
- [6] Schaper, Kalkner, Plath. "Synchronous multi-terminal on-site PD measurements on power transformers", 14th International Symposium on High Voltage Engineering, Beijing/P.R.China, 2005
- [7] Obralic, Kalkner et al. "Verbesserte Zustandsbewertung durch neue Auswerteverfahren bei der Synchronen Mehrstellen-TE-Messung an Hochspannungsmaschinen," ETG conference on Diagnostic, Kassel, Germany, 2006
- [8] Weissenberg, Farid, Plath, Rethmeier, Kalkner: "On-Site PD Detection at Cross-Bonding Links of HV Cables", CIGRE Session 2004 - Paris, France, 2004