

Partial Discharge Measurements on Power Transformers: Case studies

Dr. Kay Rethmeier, OMICRON, Austria

Introduction

Partial discharges in transformers can lead to corrosion on solid insulating materials and thus cause a breakdown of the concerned operating component in the long term. PD processes can also lead to decomposition and pollution of the insulating oil as a result of which the insulation properties of the oil cannot be guaranteed.

This is why measuring partial discharges is mandatory for new transformers and sometimes even in case of major repairs. PD measurement can also provide information about the ageing condition of service-aged transformers and thus enable conclusions about their remaining lifetime. In such cases, specific phase-related representations (PARD, fingerprints) can assist the identification of the fault type and, if necessary, a more precise localization of the fault [1].

The digital PD measurement system MPD 600 from OMICRON [2] is suitable for test facility measurements as well as for measurements in the field under strongly interfering environmental conditions and thus provides an estimable contribution to the maintenance of quality and value of expensive transformers.

PD measurement system MPD 600

The IEC 60270 certified digital PD measurement system MPD 600 [3] is able to perform synchronous multi-channel measurements. In contrast to conventional multiplexed systems with measuring channel switching, the MPD 600 allows a really simultaneous acquisition of PD signals and thus enables the application of latest methods for noise and interference suppression.

The measurement system consists of one or more acquisition units, an optical USB interface unit and a PC with the mtronix PD software installed (see Fig. 1).



Fig. 1: MPD 600 PD measurement system (measurement impedance, acquisition unit, USB interface unit and notebook)

The PD signals are filtered by an anti aliasing filter and then amplified and digitized (see Fig. 2). An amplitude

quantization of 14 bits and a sampling rate of 64 MS/s enable the acquisition of PD pulses with an accuracy of approx. 2 ns. The quasi-integration used to determine the electric charge is implemented by completely digital band-pass filters. The center frequency for the digital filter can be chosen in the range from 0 Hz up to 20 MHz, and the bandwidth in certain steps between 9 kHz and 3 MHz, respectively. This way, it is possible to choose the optimum frequency band in order to avoid disturbances and to reach the best possible SNR (signal to noise ratio). This is an indispensable feature, particularly in case of noisy conditions on site.

Acquisition and storage of the test voltage signal is done with a quantization of 24 bits which makes range switching unnecessary and guarantees high accuracy over the entire measurement range.

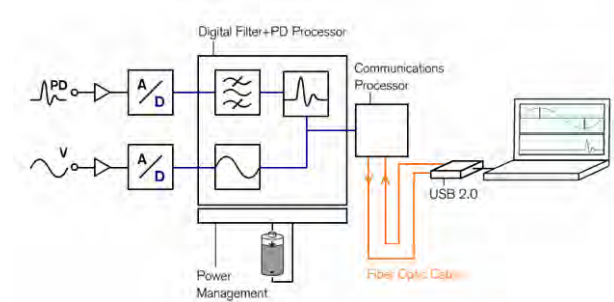

Fig. 2: Block diagram of the MPD 600

All data acquisition and pre-processing is performed in the MPD acquisition unit (see Fig. 3).

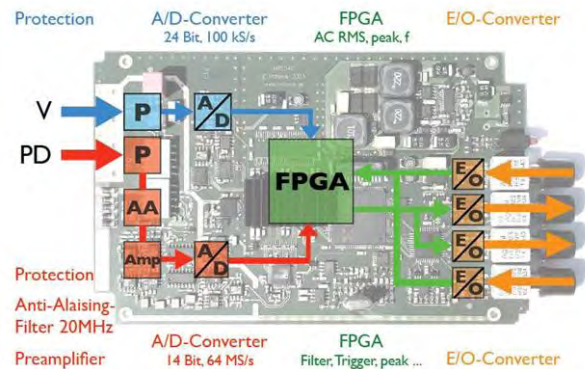

Fig. 3: Block diagram of the MPD 600 acquisition unit

For multi-channel PD measurements, it is possible to operate and control up to 960 acquisition units via a high-speed fiber-optical connection with only one PD measurement system (see Fig. 4) with a maximum number of 64 acquisition units operating in fully synchronized mode.

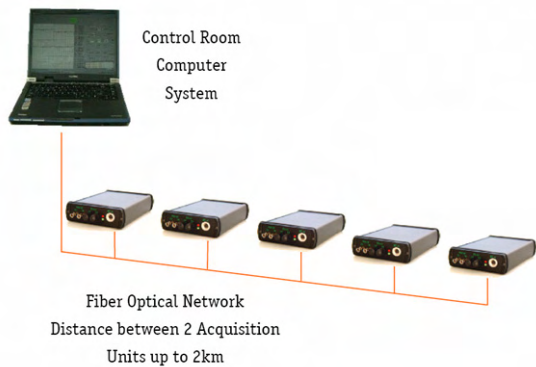

Fig. 4: Fiber-optical network for PD acquisition

For PD measurements on long cable systems, such distributed acquisition networks provide considerable advantages. For example, this system was successfully used with more than 20 acquisition units within one MPD PD measurement system during commissioning testing for a 20 km long 400 kV cable system in London [4].

For PD measurements on power transformers, it is possible to perform a simultaneous PD signal acquisition for all accessible measuring points [5]. This can, for example, be used to perform synchronous three-phase PD measurement with signal decoupling at the terminals of the primary, secondary and tertiary windings and possible accessible star point terminals.

PD signal decoupling

With the MPD 600, decoupling of PD signals from the device under test can be done either using external coupling capacitors connected in parallel to the bushings (acc. to IEC 60270:2000, see Fig. 5) or using the capacitive measuring taps of graded bushings (acc. to IEC 60076-3:2000, see Fig. 6).

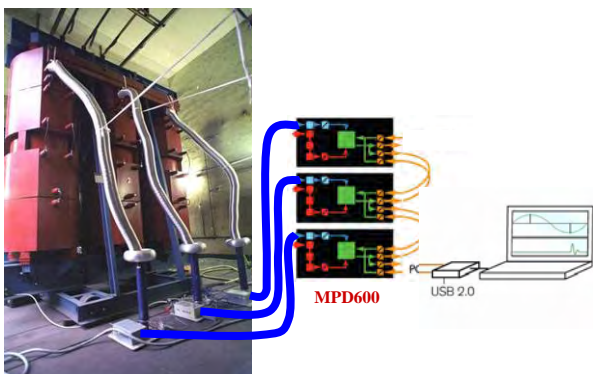

Fig. 5: 3-phase connection of the MPD 600 via coupling capacitors

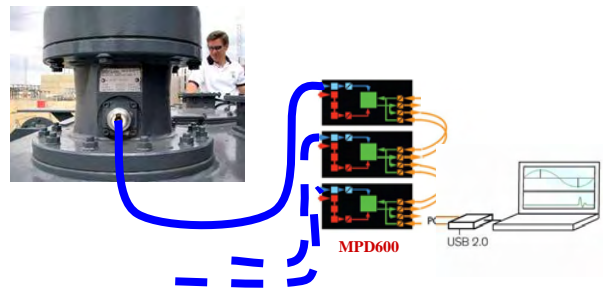

Fig. 6: 3-phase connection of the MPD 600 via measuring taps

It is also possible to perform inductive decoupling of PD signals via inductive sensors that can be connected directly to the measuring inputs of the MPD acquisition units.

Acoustic PD acquisition providing geometric PD localization is under preparation and will be available soon.

3-Phase Amplitude Relation Diagram (3PARAD)

Due to the existing coupling of the 3 phases inside a transformer, single PD pulses in one certain phase can be measured as voltage signals in all phases and acquisition units, respectively. Figure 7 shows a schematic view of the PD voltage signals acquired on the three phases for a PD fault in phase L1.

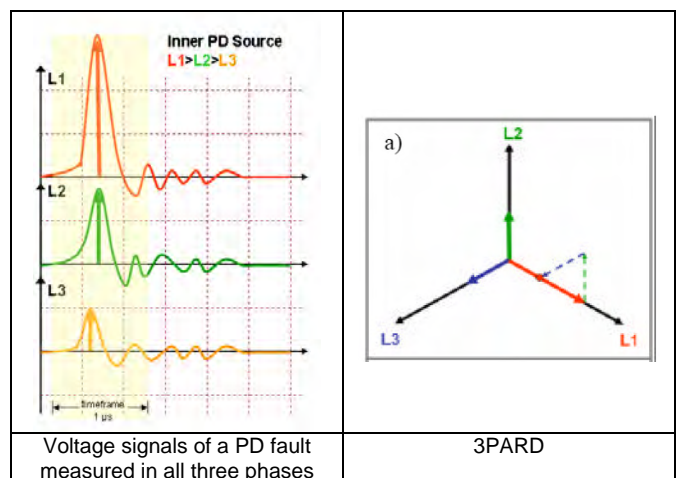

Fig. 7: 3PARAD creation from the voltage signals

As L1 is the source of the PD fault, the amplitude is highest there. Due to the galvanic coupling of the three phases, the voltage signal can also be recognized in phases L2 and L3 with reduced amplitudes.

To create a two dimensional color coded 3PARAD, the amplitude vectors of the 3 phases are added graphically with a phase shift of 120 degrees (in accordance to the phase shift of the test voltage) and then entered as a point in the diagram. The color of the corresponding pixel changes, if another vector triple also results in a point at the same position. For real PD signals, this produces point clusters near the diagram axes. Assuming that each individual PD fault source within

the insulation system leads to a unique and stable point cluster, each cluster represents one specific fault location within the transformer. The possibility of a geometric assignment within the 3PARAD is however only rudimentary (fault location near the star point or near the terminal). Pulses due to external interferences or noise (with similar amplitudes on all three phases) lead to clusters next to the origin of the 3PARAD. This allows a clear separation of PD faults from noise and interferences.

Fig. 8 shows a typical 3PARAD of a synchronous three-phase PD measurement with multiple PD fault locations.

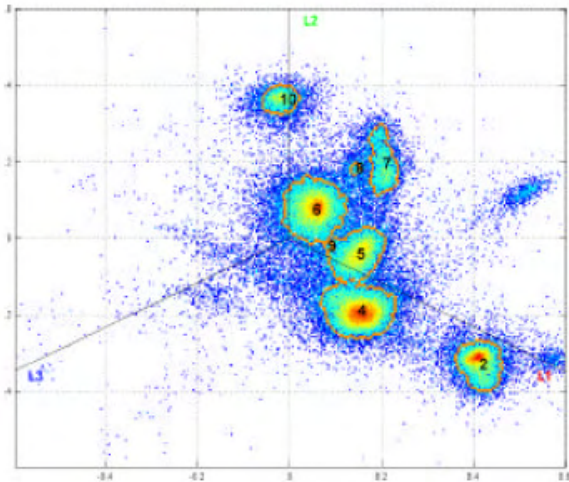

Fig. 8: 3PARAD of a three-phase PD measurement

Case studies

The following case studies describe some PD measurements on transformers using examples from practice. We apologize that we cannot publish the complete sets of measurement data for the following examples, since this sensitive information about the condition of the transformers would allow conclusion about the quality level of the manufacturer.

PD measurement: 132 kV / 20 kV power transformer

Synchronous three-phase PD measurement was performed on a 40 MVA 136 kV / 20 kV transformer in the unshielded high-voltage test hall of a transformer manufacturer. The test hall was connected to the manufacturing building without any structural separation. Inside the manufacturing area, cranes, electric welding machines and other electric machines that are able to considerably interfere sensitive PD measurements were in operation during the PD measurement.

Decoupling of PD signals was done directly at the measuring taps of the bushings. Fig.9 shows the transformer bushings with one of the three connected MPD acquisition units; Fig.10 shows the direct connection to the measuring tap.

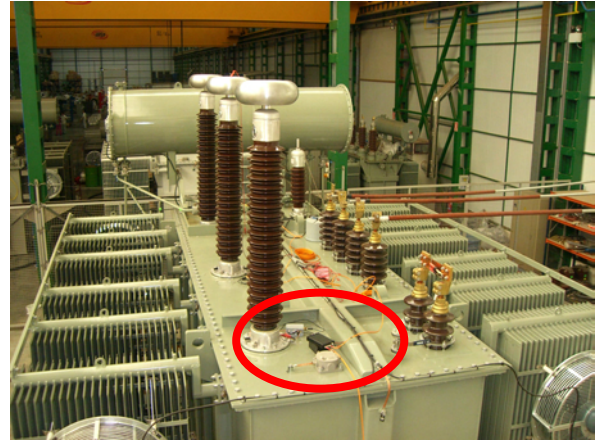

Fig. 9: MPD 600 near the bushing's base

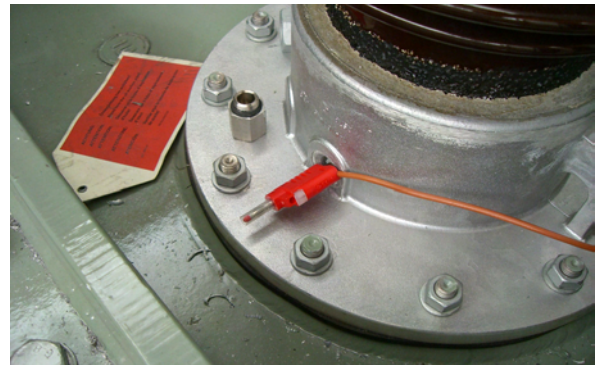

Fig. 10: Direct connection to the capacitive measuring tap

The only connection between the transformer and the computer used for the measurement is one fiber-optical twin line. This does not only show the low efforts required for wiring but also demonstrates the maximum safety obtained through the optical separation of the operators from high voltage parts.

The 3PARAD very clearly shows the PD activities in all three phases (Fig. 11).

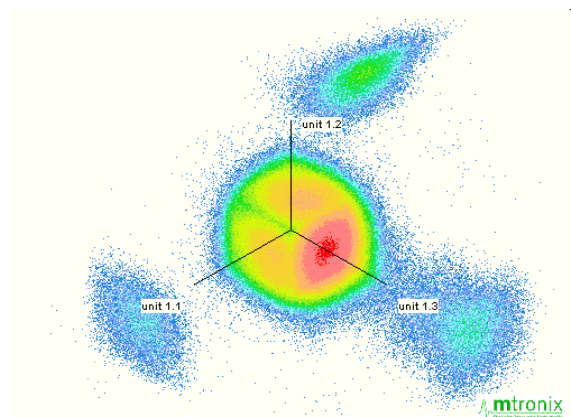

Fig. 11: 3PARAD of the PD measurement, PDs on all 3 phases
The diagram shows four large point clusters at characteristic positions. Apart from one larger cluster in the origin of the diagram (caused by noise and interferences), a total of three further clusters are visible for the phases. Figure 12 shows the inverse transformation of the 3PARAD clusters to the common

histogram representation (PD fingerprint) and a comparison of the fingerprint measured by conventional methods (left column) with the 3PARD filtered fingerprint (right column).

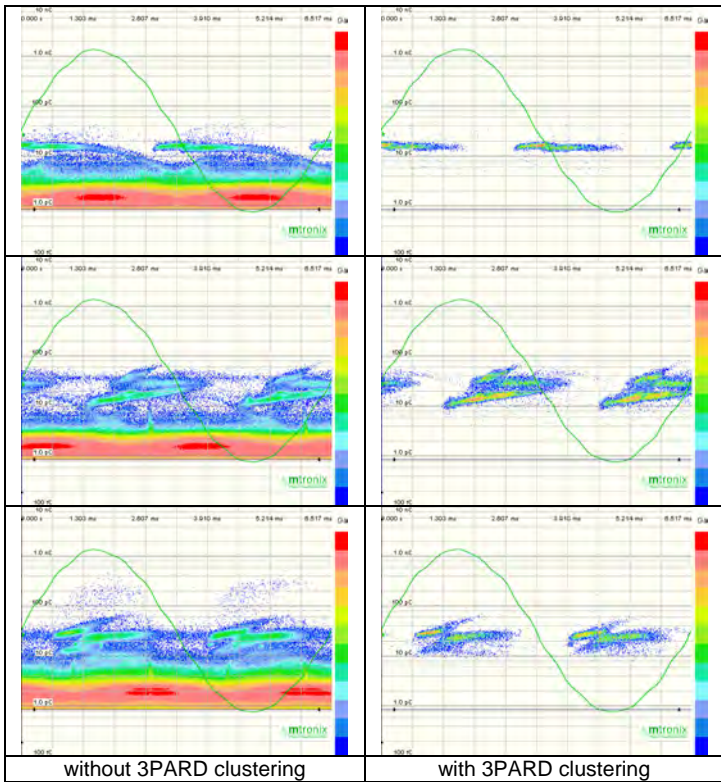

Fig. 12: Comparison of the fingerprints for L1, L2 and L3

The PD clusters remaining after 3PARD clustering show the partial discharges of the corresponding phases with a high grade of noise and interference suppression.

PD measurement: 30 MVA 115 kV / 11.3 kV power transformer

After repair of a defective 30 MVA transformer that required draining of the transformer oil, synchronous 3-phase PD measurement was performed to ensure the quality of work. Decoupling of PD signals was done directly at the measuring taps of the bushings. Fig. 13 shows the operation of the PD measurement system MPD 600 using a notebook in safe distance to the device under test in the background.



Fig. 13: PD measurement using a notebook

Fig. 14 shows a typical PD pattern with additional phase-locked interference signals and background noise as recorded during three-phase induced voltage testing.

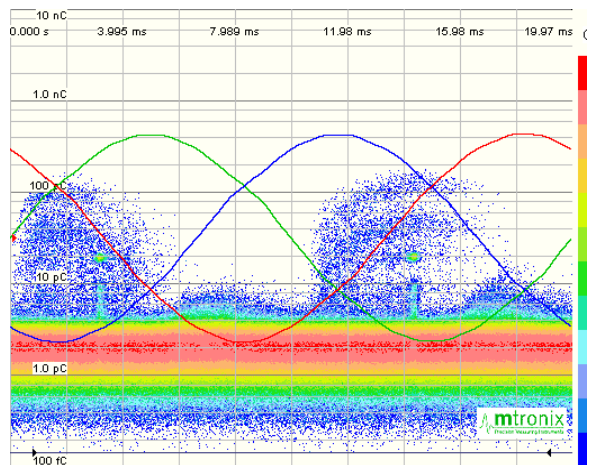

Fig. 14: PD pattern on L1

3PARD clustering allows a clear separation of the individual pulse sources. Fig. 15 shows the individual 3PARD clusters and the corresponding fingerprints.

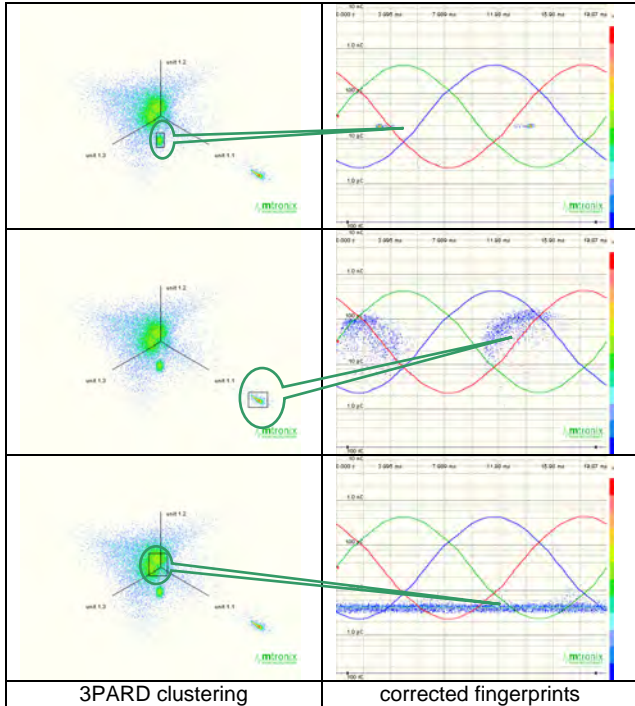

Fig. 15: Separation of 3PARD clusters

3PARD clustering enables a clear separation of the PD fault (Fig. 15, line in the middle) from an external phase-locked interference (upper line) and the statistically distributed background noise (lower line).

PD measurement: 1200 MVA 400 kV / 400 kV transformer

PD measurement on the high voltage windings of a 1200 MVA phase-shifting transformer was performed in the high voltage hall of a major transformer manufacturer. Decoupling of PD signals was done at the measuring taps of the bushings using short connecting leads. Fig. 16 shows the MPD acquisition unit, the battery for potential-free operation and an additional measurement impedance mounted directly beside the measuring tap of the bushing.

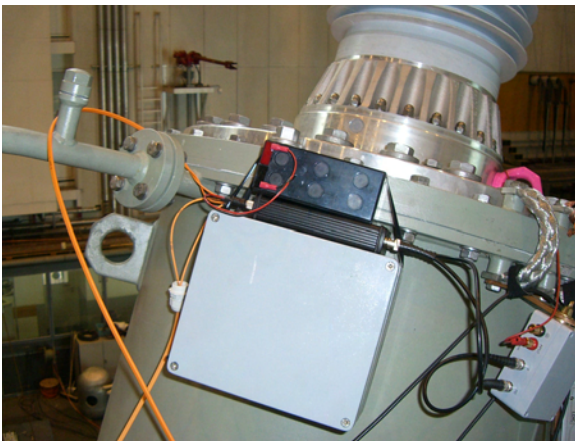

Fig. 16: PD decoupling at the measuring tap of the bushing

Keeping the electrical connecting leads as short as possible leads to smallest possible loops and minimum external interferences. In contrast to this, the length of the fiber-optical connections has no negative influences to the measuring sensitivity.

Fig. 17 shows the 3PARD of the synchronous three-phase PD measurement.

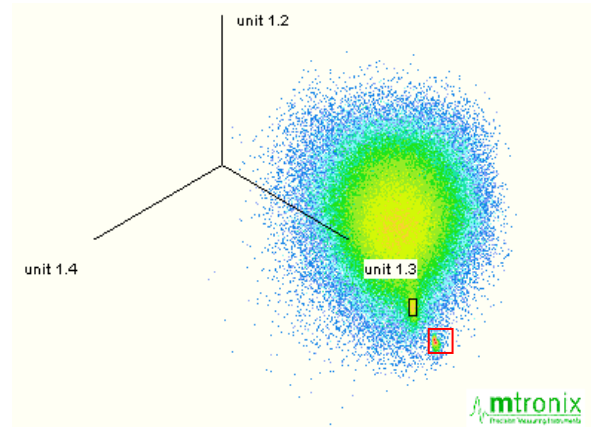

Fig. 17: 3PARD of the PD measurement, 2 PD clusters (rectangles)

The diagram shows two different rectangular areas (black rectangle, red rectangle) that indicate two different PD fault sources inside the concerned high voltage winding. Fig. 18 shows the corresponding fingerprint representations describing the PD activities in the faulty phase.

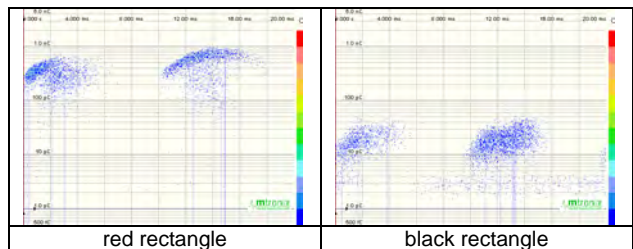

Fig. 18: PD fingerprints of two 3PARD areas in Fig. 17

PD measurement: 790 MVA 400 kV / 200 kV power transformer

As part of a product demonstration for the MPD 600, partial discharge measurement on an autotransformer was performed in the test facility of a major transformer manufacturer. Figure 19 shows the high voltage bushings on the upper part of the transformer with anti-corona spheres or twin toroids mounted in order to avoid corona discharges.



Fig. 19: Transformer in the test hall

PD decoupling was performed at the capacitive measuring tap of the bushings using a ready-mounted measurement impedance of the customer (see Fig. 20).

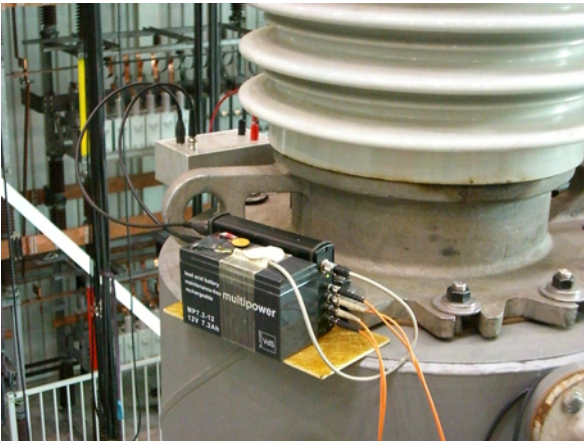

Fig. 20: PD decoupling at the measuring tap of the bushing

With the help of prepared measurements of the transformer manufacturer, the PD fault could already be localized to phase L1 (400kV level) or S1 (200 kV level). In this case, the 3-channel PD measurement using the MPD 600 was not performed at the three phases L1, L2 and L3 but at the measuring taps of the bushings for L1, S1 and N instead.

Fig. 21 shows the conventionally measured fingerprint at measuring point L1.

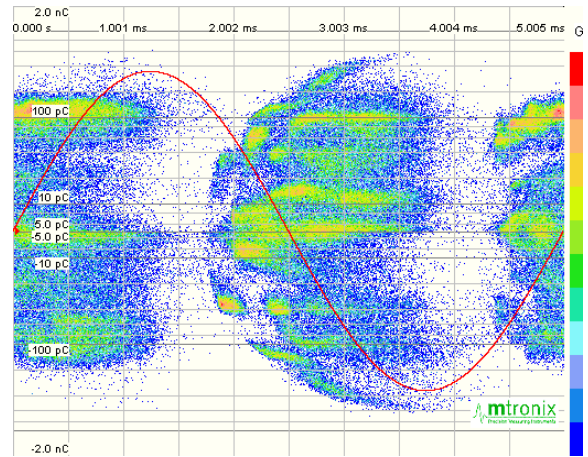

Fig. 21: Fingerprint of the PD measurement at L1 with several superimposed PD faults

The figure shows several PD patterns that superimpose to one complex composed diagram. The 3PAR (see Fig. 22) separates these superimpositions into five individual areas.

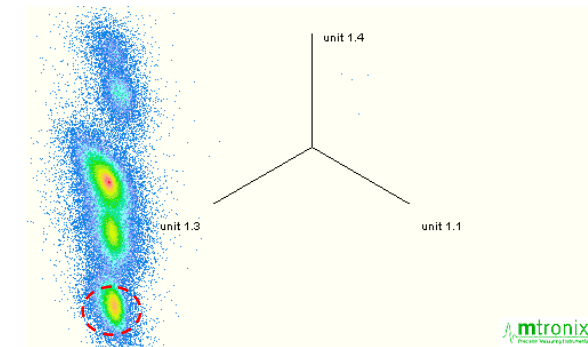

Fig. 22: 3PAR of the PD measurement

An inverse transformation of these individual clusters provides fingerprint representations of the PD measurement, separated according to the PD fault sources. Fig. 23 shows a typical fingerprint (highlighted cluster in Fig. 22) as it occurs in the transformer as a result of a single PD fault mechanism or PD fault source.

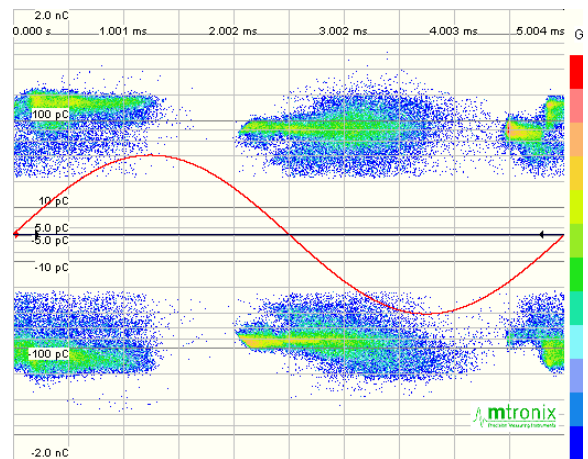

Fig. 23: Fingerprint of the PD measurement at L1, only one PD fault considered (after 3PAR filtering)

PD measurement: 112 MVA 110 kV generator transformer

PD measurement on transformers that are directly connected to modern totally encapsulated installations via transformer-mounted cable terminations is often difficult. There, usually no capacitive measuring taps are available that could be used for PD signal decoupling. Therefore, alternative decoupling methods have to be used [7, 8].

The analysis of the insulating oil of a 112 MVA generator transformer installed in a district heating power station showed conspicuous gas concentrations. PD measurement should point out whether these changes in the oil were caused by discharges inside the transformer. PD signal decoupling was performed using RF transformers mounted around the ground connections of the 110 kV cable inlets of the cable terminations of the transformer. Fig. 24 and 25 show the cable inlets with the decoupling units for synchronous three-phase measurement.



Fig. 24: 110 kV transformer inlet

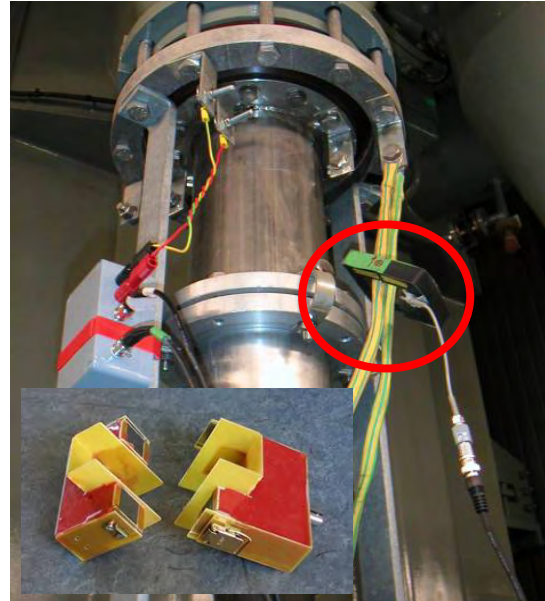

Fig. 25: RF transformer on the shielding connection, two-part design (see small figure)

No partial discharges could be detected inside the transformer when AC voltage was applied (excitation on high voltage side, transformer in no-load condition). The occasional spurious pulses with electrical charges of maximally 10 pC acquired on the three measurement channels and the acquired background noise with electrical charges < 2 pC are displayed in the 3PARD as symmetrical interferences without phase reference and are thus irrelevant (see Fig. 27).

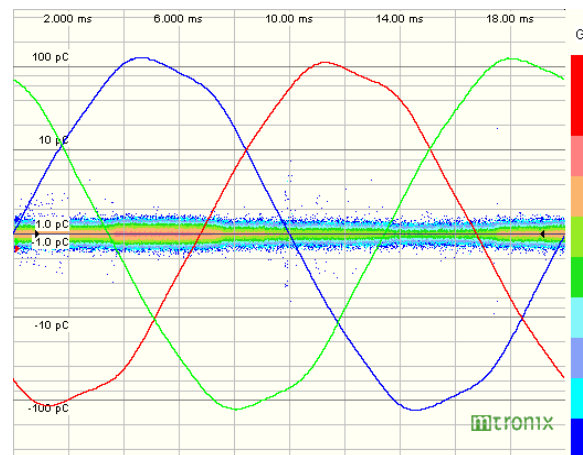

Fig. 26: Fingerprint, no PD activities

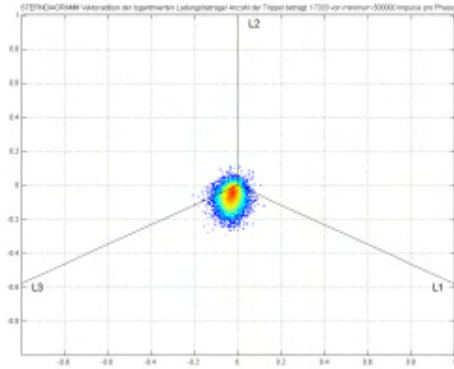

Fig. 27: 3PARD, no PD activities

PD measurement could not deliver any information about the reason for the changed gas-in-oil values but it was able to exclude internal partial discharges (in no-load condition) with high certainty. Measurement and acquisition of single interferences and spurious pulses (e.g. produced by switching on the device under test) showed that PD decoupling using RF transformers worked successful in this case. It should be emphasized that the reached measuring sensitivity of < 2 pC could never be obtained by alternative decoupling methods, e.g. the PD decoupling via coupling capacitors on the other end of the cable.

Summary

The digital multi-terminal PD measurement system MPD 600 from OMICRON allows synchronous PD measurement for all possible decoupling sources on a transformer. Coupling can be done using additional external coupling capacitors, using the capacitive measuring taps on the bushings or using inductive sensors. Three-phase PD measurement (if applicable, with star point) can be performed as part of the induced voltage testing and can thus not only provide information about a PD faulted phase but is also able to uncover several PD sources within one winding of the device under test in real time by means of the 3PARD representation. Inverse transformation of individual PD fault sources to the known phase-related histogram (PRPD, fingerprint) is also performed in real time. Up to now, it was only possible to view and evaluate the fingerprints of multiple superimposing PD faults. OMICRON's 3PARD method makes it for the first time possible to concentrate to specific PD faults and to analyze them.

Literature

- [1] Natrass: Partial discharge measurement and interpretation, IEEE Electrical Insulation Magazine, IEEE, 1988
- [2] Omicron electronics: "MPD 600 - Product brief and specification", Klaus, Austria, 2007
- [3] Holle, Plath, Schon and Lucas: "Type testing a digital PD measuring system according to IEC 60270", ETG conference on Diagnostic, Kassel, Germany, 2006
- [4] Sutton, Plath and Schroeder: "The St. Johns Wood – Elstree Experience – Testing a 20km long 400kV XLPE-insulated Cable System after installation", 7th International Conference on Insulated Power Cable Jicable07, France, Versailles, 2007
- [5] K.-D.Plath, R.Plath, Emanuel and Kalkner: "Synchrone dreiphasige Teilentladungsmessung an Leistungstransformatoren vor Ort und im Labor", ETG conference on Diagnostic, Berlin, Germany, 2002
- [6] Schaper, Kalkner, Plath. "Synchronous multi-terminal on-site PD measurements on power transformers", 14th International Symposium on High Voltage Engineering, Beijing/P.R.China, 2005
- [7] Schaper, Kalkner, Plath: "Mehrstellen-TE-Messung an Leistungstransformatoren bei ungünstigen Vor-Ort-Verhältnissen", ETG conference on Diagnostic, Kassel, Germany, 2006
- [8] Rethmeier: "Neue Auskoppelverfahren und Sensoren zur Vor-Ort-Teilentladungsmessung an Hochspannungs-Kabelanlagen", Dissertation TU-Berlin, Fakultät IV - Elektrotechnik und Informatik, Institut für Energie- und Automatisierungstechnik, Fachgebiet Hochspannungstechnik, Berlin, Germany, 2006